

ITEM NO.	PART NO.	DESCRIPTION	QTY.
1	P622	housing, upper clear, handtool	1
2	P623	housing, lower black, handtool	1
3	A935	sol hose, pigtail, 1/8 x 7 1/2"	1
4	B101	quick disconnect, 1/4" mqd x 1/4" fpt	1
5	B144B	valve assy, hand tool, 8400P	1
6	H792	nut, lock, 6-32, nylon insert, s/s	2
7	P625	lever, upholstery tool	1
8	H458	nut, lock, 10-32, thin pattern	1
9	H788	screw, 10-32 x 1-3/8", phil pan, s/s	1
10	B163	jet, 1/8", vv8002, brass	1
11	B657	elbow, 45 deg street, 1/8" mpt x 1/8" fpt	1
12	H791	screw, 6-32 x 1-1/8", phil pan, s/s	2
13	P624	glide, upholstery tool	1
14	H794	screw, #8 x 1/2", phil pan, s/s	6
15	G214	o-ring, 1/4" OD x 1/8" ID	6

REVISIONS			
REV.	DESCRIPTION	DATE	APPROVED
OD	ORIGINAL DRAFT	10/2017	JFL

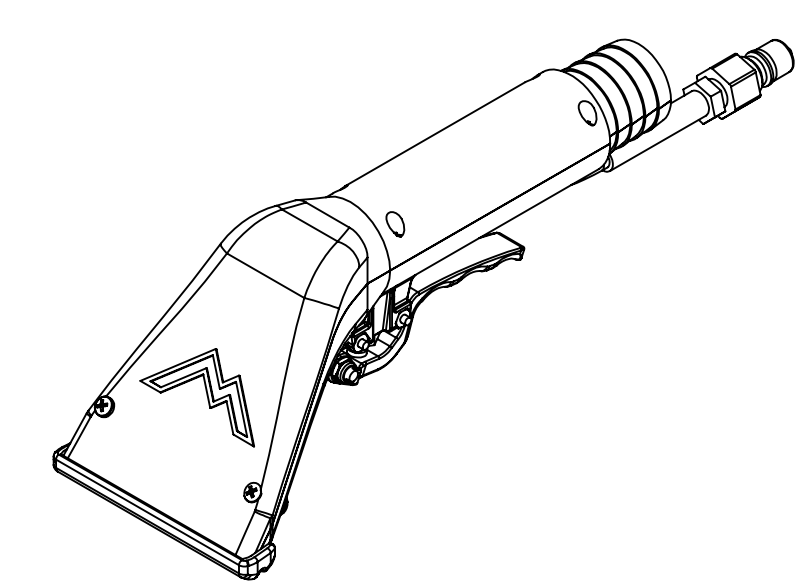
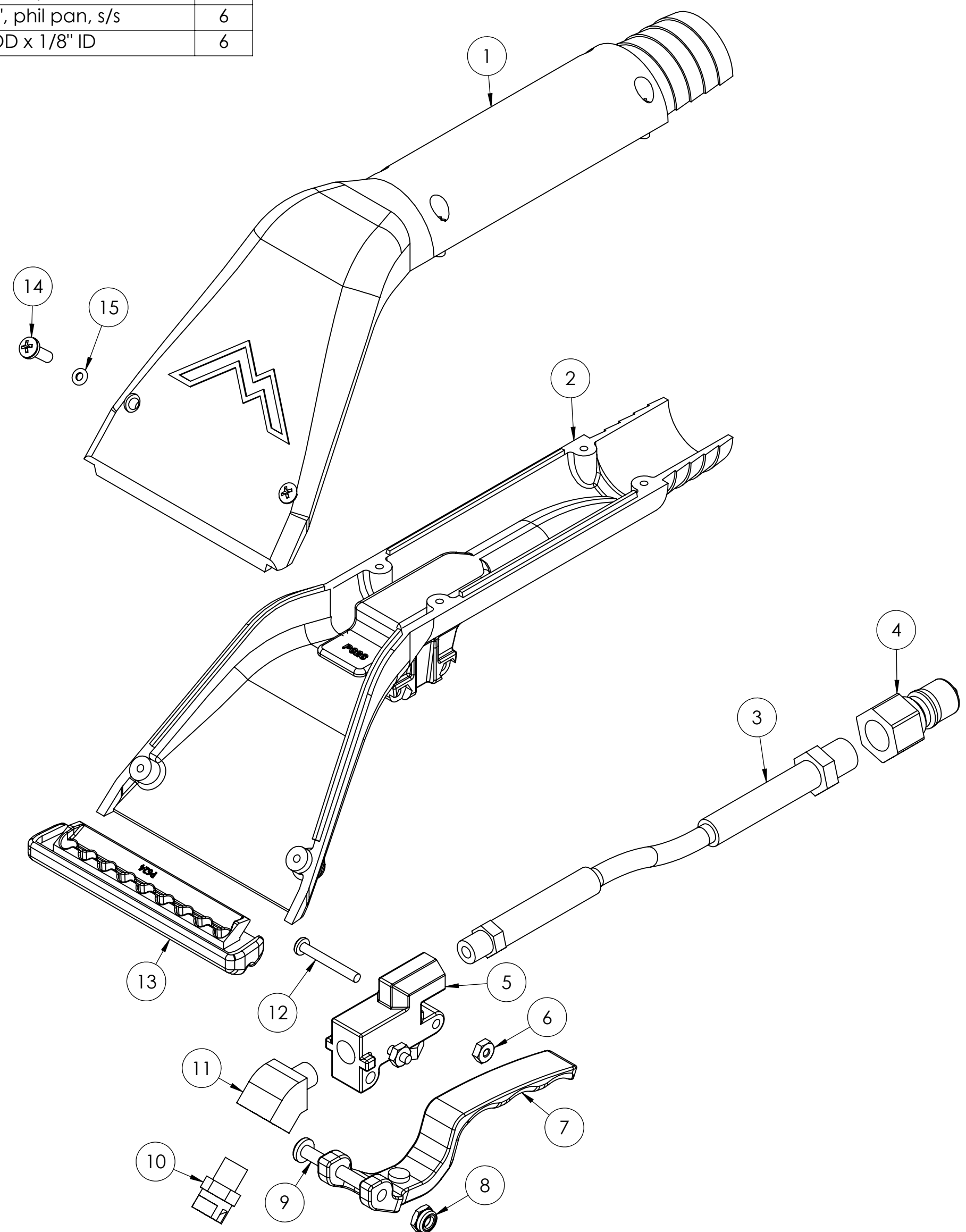

NAME	DATE	<b>MYTEE</b> 858-679-1191	
DRAWN M.LaBarbera	10/2017	TITLE: <b>Air Lite</b>	
CHECKED		SIZE <b>C</b>	DWG. NO. <b>8400P</b>
COMMENTS:		SCALE: 1:5	REV <b>OD</b>
<small>PROPRIETARY AND CONFIDENTIAL</small> <small>THE INFORMATION CONTAINED IN THIS DRAWING IS THE SOLE PROPERTY OF MYTEE LLC. ANY REPRODUCTION IN PART OR AS A WHOLE WITHOUT THE WRITTEN PERMISSION OF MYTEE LLC IS PROHIBITED.</small>		DO NOT SCALE DRAWING	SHEET 1 OF 1